



Network Modem Communications Interface

3-NSHM1 & 3-NSHM2



Overview

EST3 networks easily configure for use over existing copper telephone lines using the 3-NSHM Short Haul Modem Communications Interface.

The 3-NSHM electronics card, plugs right into the 3-CPU3. A ribbon cable connects the 3-CPU3 directly to the modem interface card. The interface card mounts on the right rear of a 3-CHAS7 chassis. No local rail space is used. The 3-NSHMs requires the 3-MPFIB mounting bracket for 3-CAB5 enclosure mounting.

3-NSHM1 provides a single short haul modem connection and converts the signal to RS-485 format for hard wired network connections to additional network nodes. The 3-NSHM2 provides two short haul modem connections for use when two short haul modems are required for connections to additional network nodes.

Each short haul modem circuit consists of *two pairs* of twisted pair cable. Network wiring can be installed as Class A or Class B, depending on installation.

The 3-NSHM1 also supports copper wire connections, permitting network data communications format changes from short haul modem connection to direct RS-485 and from direct RS-485 to short haul modem connections as job conditions require.

The 3-NSHM provides an integral test signal, making the use of a separate signal source unnecessary. This can reduce setup and trouble shooting time. A standby battery connection is provided to maintain communications through the node in the event that power is removed for servicing the node.

The 3-NSHMs are *compatible* with EST3 systems using digitized audio, however the 3-NSHMs *do not* transmit the digitized audio signal between nodes.

Standard Features

- Class A or Class B EST3 Data Network Connections
- Up to 5 miles between nodes
- Uses existing copper telephone lines
- Supervised
- Integral test modes

Application

The 3-NSHM short haul modems provide long distance network communications between nodes, typically using existing telephone conductors. A model GFD Ground Fault Detector should be used in applications where ground fault detection is required.

Network B to A wiring using the NSHM1

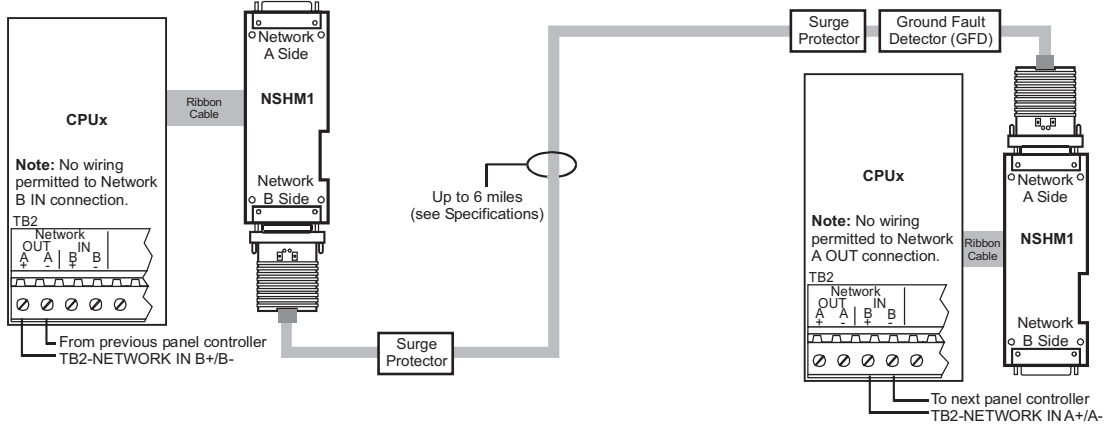

Network A to B wiring using the NSHM1

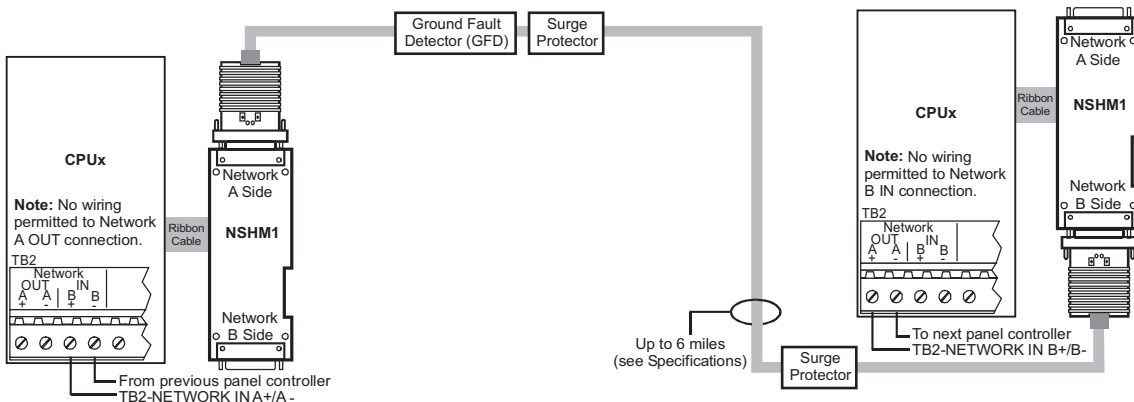

Network wiring using the NSHM2

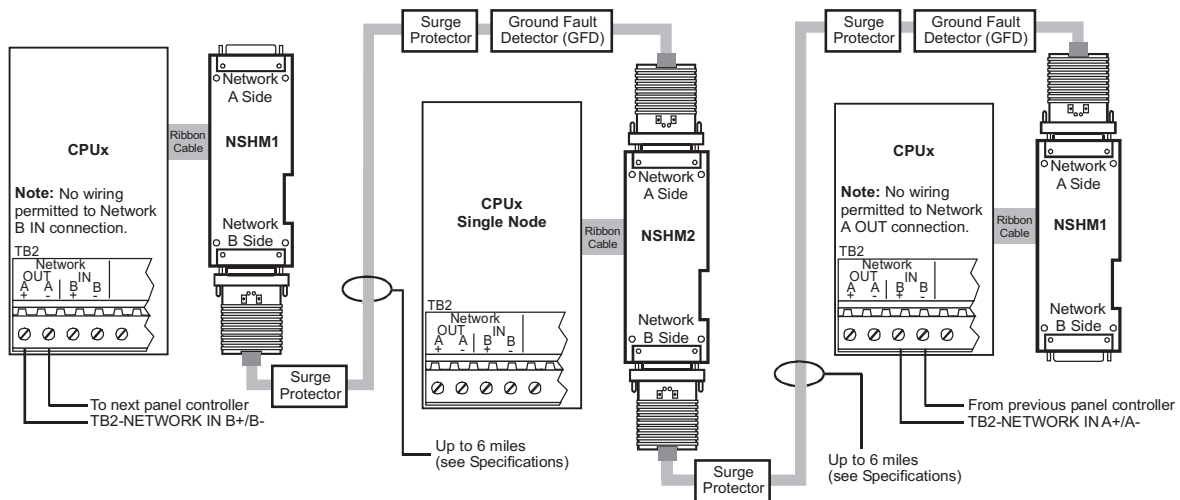

Notes

1. Add surge suppressors when wiring between buildings.
2. Monitor GFD contacts with system input module.

Installation and Mounting

Chassis Mounting

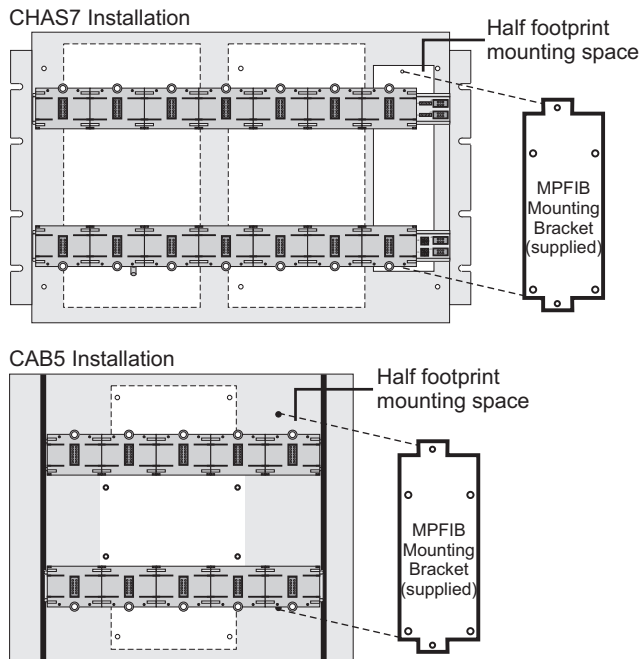

Module Connections

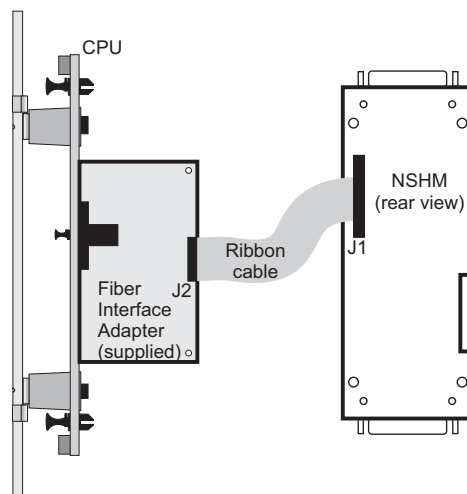

Engineering Specification

The intra-node communications links for network shall utilize copper and/or fiber optic connections. The communications interface card shall provide Class B <Class A> connections. It shall be possible to convert from modem connections to hard wired RS-485 wiring or from hardwired RS-485 wiring to modem wiring at any network node. The short haul modem communications interface card shall have provisions for testing the modem(s) and its connections for maintenance and troubleshooting purposes.

Specifications

Agency Listings	UL, ULC						
Installation	Connector J2 of 3-CPU3. Modem card mounts on bracket under 3-CHAS7 or on 3-MPFIB bracket in 3-CAB5 enclosure.						
Network Data Circuit	<table border="0"> <tr> <td>Configuration</td> <td>Class B or Class A</td> </tr> <tr> <td>Data Rate</td> <td>19.2 Kb, or 38.4 Kb</td> </tr> <tr> <td>Isolation</td> <td>Optically isolated from previous 3-CPU3</td> </tr> </table>	Configuration	Class B or Class A	Data Rate	19.2 Kb, or 38.4 Kb	Isolation	Optically isolated from previous 3-CPU3
Configuration	Class B or Class A						
Data Rate	19.2 Kb, or 38.4 Kb						
Isolation	Optically isolated from previous 3-CPU3						
Hard Wired RS-485 Circuit	<table border="0"> <tr> <td>Circuit Length</td> <td>5,000 ft (1,524 m) max. between any three panels</td> </tr> <tr> <td>Circuit Resistance</td> <td>90 Ohms, max.</td> </tr> <tr> <td>Circuit Capacitance</td> <td>0.3 mF, max.</td> </tr> </table>	Circuit Length	5,000 ft (1,524 m) max. between any three panels	Circuit Resistance	90 Ohms, max.	Circuit Capacitance	0.3 mF, max.
Circuit Length	5,000 ft (1,524 m) max. between any three panels						
Circuit Resistance	90 Ohms, max.						
Circuit Capacitance	0.3 mF, max.						
Wire Type	Twisted pair						
Test Functions	Local analog loopback and remote digital loopback						
Power Consumption Supervisory or Alarm	3-NSHM1: 79 mA @ 24 VDC; 3-NSHM2: 105 mA @ 24 VDC						
Operating environment	32°F -120°F (0°C - 49°C) @93% RH, Non-condensing						
Compatible with	3-CPU1, 3-CPU3						
Maximum per network	20 (EST3 Version 3.5)						

Short Haul Modem Circuit	19 AWG	24 AWG	26 AWG
Wiring Configuration	TWO Twisted Pair	TWO Twisted Pair	TWO Twisted Pair
Max. Resistance	16.3 Ohms/1000 ft (53.5 Ohm/km)	51.65 Ohms/1000 ft (169.5 Ohm/km)	82.35 Ohms/1000 ft (270.2 Ohm/km)
Max. Capacitance	83 nf/mi [15.72 pf/ft] (151.6 nf/km)	83 nf/mi [15.72 pf/ft] (151.6 nf/km)	83 nf/mi [15.72 pf/ft] (151.6 nf/km)
Max. Distance mi (km)			
	@ 38.4Kb	6 (9.7)	3.5 (5.6)
	@ 19.5Kb	9 (14.5)	5 (8)
			2 (3.2)
			3 (4.8)



Detection & alarm since 1872

U.S.
T 888-378-2329
F 866-503-3996

Canada
Chubb Edwards
T 519 376 2430
F 519 376 7258

Southeast Asia
T : +65 6391 9300
F : +65 6391 9306

India
T : +91 80 4344 2000
F : +91 80 4344 2050

Australia
T +61 3 9239 1200
F +61 3 9239 1299

Europe
T +32 2 725 11 20
F +32 2 721 86 13

Latin America
T 305 593 4301
F 305 593 4300

utcfireandsecurity.com

© 2010 UTC Fire & Security.
All rights reserved.

Ordering Information

Catalog Number	Description	Shipping Wt. lb (kg)
3-NSHM1	Network Short Haul Modem Communications Interface, single modem connection	1 (.45)
3-NSHM2	Network Short Haul Modem Communications Interface, two modem connections	1 (.45)
GFD	Ground Fault Detection Module	1 (.45)